

# Truck

O W N E R S

# Manual



**CHRYSLER AUSTRALIA LIMITED**

MAPLE AVENUE

KESWICK

SOUTH AUSTRALIA

# Truck

O W N E R S

# Manual



**CHRYSLER AUSTRALIA LIMITED**

MAPLE AVENUE

KESWICK

SOUTH AUSTRALIA

Copyright 1953

## TABLE OF CONTENTS

	Page
INTRODUCTION .....	3
LICENCE DATA .....	4
PROPER CARE OF NEW ENGINES .....	5
INSTRUMENTS AND CONTROLS .....	6
OPERATING INSTRUCTIONS .....	9
LUBRICATION .....	13
BRAKES .....	22
CLUTCH .....	28
COOLING SYSTEM .....	30
ELECTRICAL SYSTEM .....	33
THE ENGINE .....	34
TRANSMISSION .....	34
REAR AXLE .....	35
WHEELS AND TYRES .....	39
CARE OF FINISH .....	42
CAPACITIES .....	43
SERVICE STANDARDS .....	45

## INTRODUCTION

### **THIS BOOK POINTS THE WAY TO THE GREATEST POSSIBLE PERFORMANCE FROM YOUR NEW TRUCK**

You have bought this new truck and, of course, you want to obtain from it the highest possible degree of satisfaction. Reading this book, therefore, is a matter of vital importance to you. You have invested **several hundred pounds of your money**; now let us **ask you to invest a few minutes of your time**. We feel that you are certain to find both the time and the money well spent.

Here is a new type of instruction book—easy to read, written in non-technical language, with a lot of clear, readily understandable illustrations—a book in which any desired information may be quickly located. We urge that you—and everybody else who may drive the truck—read it carefully and always keep it available for ready reference.

Proper lubrication is a vital factor in promoting the long life and smooth operation which has been built into your truck. We, therefore, refer you particularly to the Lubrication Section of this manual.

Communications with reference to your truck should give the purchase date, truck serial number and the distance it has travelled.

**CHRYSLER AUSTRALIA LIMITED  
KESWICK - SOUTH AUSTRALIA**

# HERE'S YOUR LICENCE DATA

SERIES	G.V.W.	WHEEL BASE	TAXABLE		No. OF CYLINDERS	BORE & STROKE
			H.P.	CAPACITY		
1-08AD	5,250 lbs.	108"	28.35	250.6 cu. in.	6	3-7/16 x 4 1/2
1-08AF	5,250 lbs.	108"	28.35	250.6 cu. in.	6	3-7/16 x 4 1/2
1-08AS	5,250 lbs.	108"	28.35	250.6 cu. in.	6	3-7/16 x 4 1/2
1-08BD	5,250 lbs.	108"	28.35	250.6 cu. in.	6	3-7/16 x 4 1/2
1-08BF	5,250 lbs.	108"	28.35	250.6 cu. in.	6	3-7/16 x 4 1/2
1-08BS	5,250 lbs.	108"	28.35	250.6 cu. in.	6	3-7/16 x 4 1/2
2-26AD	7,500 lbs.	126"	28.35	250.6 cu. in.	6	3-7/16 x 4 1/2
2-26AF	7,500 lbs.	126"	28.35	250.6 cu. in.	6	3-7/16 x 4 1/2
2-26AS	7,500 lbs.	126"	28.35	250.6 cu. in.	6	3-7/16 x 4 1/2
2-26BD	7,500 lbs.	126"	28.35	250.6 cu. in.	6	3-7/16 x 4 1/2
2-26BF	7,500 lbs.	126"	28.35	250.6 cu. in.	6	3-7/16 x 4 1/2
2-26BS	7,500 lbs.	126"	28.35	250.6 cu. in.	6	3-7/16 x 4 1/2
2-33AD	8,000 lbs.	133"	28.35	250.6 cu. in.	6	3-7/16 x 4 1/2
2-33AF	8,000 lbs.	133"	28.35	250.6 cu. in.	6	3-7/16 x 4 1/2
2-33AS	8,000 lbs.	133"	28.35	250.6 cu. in.	6	3-7/16 x 4 1/2
3-59AD	12,320 lbs.	159"	28.35	250.6 cu. in.	6	3-7/16 x 4 1/2
3-59AF	12,320 lbs.	159"	28.35	250.6 cu. in.	6	3-7/16 x 4 1/2
3-59AS	12,320 lbs.	159"	28.35	250.6 cu. in.	6	3-7/16 x 4 1/2
6-71AD	18,500 lbs.	171 1/2"	28.35	250.6 cu. in.	6	3-7/16 x 4 1/2
6-71AF	18,500 lbs.	171 1/2"	28.35	250.6 cu. in.	6	3-7/16 x 4 1/2
6-71AS	18,500 lbs.	171 1/2"	28.35	250.6 cu. in.	6	3-7/16 x 4 1/2
8-65AD	21,000 lbs.	165"	28.35	250.6 cu. in.	6	3-7/16 x 4 1/2
8-65AF	21,000 lbs.	165"	28.35	250.6 cu. in.	6	3-7/16 x 4 1/2
8-65AS	21,000 lbs.	165"	28.35	250.6 cu. in.	6	3-7/16 x 4 1/2
8-71AD	21,000 lbs.	171 1/2"	28.35	250.6 cu. in.	6	3-7/16 x 4 1/2
8-71AF	21,000 lbs.	171 1/2"	28.35	250.6 cu. in.	6	3-7/16 x 4 1/2
8-71AS	21,000 lbs.	171 1/2"	28.35	250.6 cu. in.	6	3-7/16 x 4 1/2
8-71AD-D	21,000 lbs.	171 1/2"	29.4	288.6 cu. in.	6	3 1/2 x 5
8-71AF-D	21,000 lbs.	171 1/2"	29.4	288.6 cu. in.	6	3 1/2 x 5
8-71AS-D	21,000 lbs.	171 1/2"	29.4	288.6 cu. in.	6	3 1/2 x 5

## THE PROPER CARE OF NEW ENGINES

The life of a truck depends on the care it receives for the first 500 to 1500 miles of operation, and every owner should be carefully instructed along these lines when delivery is made to him.

**New engines should never be driven in excess of 25 miles per hour in direct drive for the first 500 miles of operation.** During the next 2,000 miles of operation the speed may be **gradually** increased to complete the breaking-in process. The truck must not be driven at continued high speeds for the first 2,500 miles. **Be sure that the engine has been driven at least 4,000 miles before attempting to make it produce maximum power.** This mileage is necessary to make sure that all internal engine friction has been minimized.

Gradually burnishing the bearing surfaces, by careful initial use, will create a very hard and smooth glazed surface, which is most desirable and has much to do with the length of the life of the parts before wear makes replacement necessary.

In new engines the oil should be drained after the first 500 miles of operation and refilled with an oil as recommended in the "Lubrication" section of this manual.

## COLD ENGINES

When starting cold engines (whether new or not) care should be exercised during the warming up period. The engine should always be allowed to run at idle speed for a few minutes before driving the truck, and then the truck should be driven slowly until normal operating temperature is reached. It must be remembered that the cause of damage to new bearings and pistons, as well as cold engines, is principally due to extremely high temperatures of the frictional surfaces. These high temperatures are the result of excessive speeds of the rotating or reciprocating parts. Some owners may drive their trucks within the recommended speed in low and second gear, yet the engine will be turning more R.P.M. than would be necessary to drive the truck 35 miles per hour in direct drive.

## INSTRUMENTS AND CONTROLS

### OIL PRESSURE GAUGE:

The oil pressure gauge should register from 30 to 45 pounds pressure at speeds above 30 miles per hour. If the gauge registers too low a pressure, especially at speeds above 30 miles per hour, or fluctuates between 10 and 45 pounds (except at slow engine speed), check the engine oil level immediately. If the engine oil is at the proper level, and the gauge still registers too low a pressure or none at all, investigate the condition at once.

### AMMETER:

The ammeter registers the rate of charge or discharge of the battery. When the electrical units are drawing more electricity than the generator is charging, the pointer on the ammeter will be on the negative (—) side of zero, and when charging more than is being consumed, the pointer will be on the positive (plus) side of zero. Electricity consumed by the starting motor is not registered by the ammeter. If, when all electrical units are switched off, the ammeter pointer registers on the negative (—) side of zero, there is a leakage of electricity somewhere in the system, and the condition should be corrected at once.

While driving the truck, the ammeter hand may gradually approach zero. This indicates that the battery requires less current at that time and the voltage regulator is preventing overcharging. The ammeter should not show more than 10 ampere charge above 30 m.p.h. after the first 30 minutes of continuous driving. If it shows more than 10 amperes, with battery specific gravity of 1.275 or higher, the voltage regulator unit should be checked.

### HEAT INDICATOR:

The heat indicator shows the temperature of the water in the engine above 100°F. Never warm the engine quickly by running it fast just after starting. When driving, glance at the heat indicator occasionally to see that it does not register too hot. If it registers 200 degrees or more, the engine is too hot, and should be stopped. Usually this is caused by insufficient water in the radiator, broken or loose fan belt. Whatever the cause of overheating may be, have the condition corrected before continuing to drive the truck.

**Do not pour cold water into an overheated engine.**

### SPEEDOMETER:

The speedometer registers the forward speed of the vehicle in miles per hour.

## **FUEL GAUGE:**

The fuel gauge operates when the ignition switch is turned to the right (clockwise). It is electrically operated and indicates the level of the fuel in the tank. The letter "E" means empty, the letter "F" means full, and " $\frac{1}{2}$ " means half full.

## **PANEL LAMP CONTROL KNOB:**

When the panel lamp control knob is turned through 90°, the instrument panel lamp circuit is connected.

## **BEAM CONTROL SWITCH:**

The beam control switch enables the operator to select either the high or low beam as driving conditions warrant. Depressing and releasing the beam control switch selects the high and low beams alternately. The lights should be on the low beam when meeting oncoming traffic or when driving on well-lit city streets.

## **IGNITION SWITCH:**

The ignition switch is turned on and off by means of the key. In the vertical position the switch is "OFF". Turning the key to the right brings it into the "ON" position. In this position the ignition and fuel gauge circuits are connected.

## **CHOKE CONTROL:**

The choke control button closes the choke or operates the Bi-Starter fitted to Solex Carburetors when pulled "out" to the limit of its travel. Pull the choke control "out" when starting a cold engine and gradually push it "in" as the engine becomes warm. When a Solex Carburettor is fitted do NOT depress the accelerator when the choke control is pulled right out for cold starting; and, a short time after the engine has started push the choke control button in half way. Always run the engine with the choke button pushed "in" as soon as possible after starting. Excessive use of the choke causes a flooding condition in the engine and excess fuel works its way past the pistons into the crankcase, diluting the engine oil. It also increases fuel consumption unnecessarily.

## **HAND THROTTLE:**

The hand throttle button is for use after starting the engine. It can also be used when starting the truck on steep hills where both feet are necessary to operate the clutch and brake pedals. Pulling the button outwards opens the throttle.

## **ACCELERATOR PEDAL:**

This is used to control the engine speed with the foot while driving the truck.



### **CLUTCH PEDAL:**

Pressing the clutch pedal down to the floor board disengages the clutch so that the transmission gears may be shifted.

### **TRANSMISSION GEARSHIFT LEVER:**

This lever controls the shifting of all gears in the transmission.

**CAUTION:** Do not attempt to start the engine unless the gearshift lever is in the neutral position or the clutch is disengaged.

### **HAND BRAKE LEVER:**

The hand brake is used principally for holding the truck while parked. When parking on a grade, turn the front wheels off the straight-ahead position. The hand brake is released when the lever is in the extreme forward position and applied when moved back toward the seat. When pulled back, the lever will lock in position but may be released by pressing the release button (on top of the lever) down and pushing the lever forward. The handbrake operating rods and compensator linkage should not be altered or adjusted.

Models 1-08, 2-26 and 2-33 (Standard equipment) are fitted with a Pull Rod type of **Hand Brake**. The brake itself is situated at the rear of the Transmission.

### **BRAKE (FOOT) PEDAL:**

The brake pedal is used to slow down or stop the vehicle.

## OPERATING INSTRUCTIONS

### YOUR TRUCK IS EASY TO DRIVE—BUT IT'S IMPORTANT TO DRIVE WELL.

Into your new truck has been built every feature known to modern automotive engineering that makes for greater driving ease, control and safety. Your truck is thoroughly responsive.

Anyone who can drive at all will find this an exceptionally easy truck to handle. But with the volume of traffic on the road to-day, and with this volume steadily increasing, it becomes more and more important that one be not merely an adequate driver, but an **expert** driver. And this truck makes it a simple matter to become an expert driver. Careful attention to the suggestions in this book will mean that you and your truck will get the best results under any given set of driving conditions.

There's more to being an expert driver than proper manipulation of the truck in action. One most important sign of the expert is the care he gives the truck. The expert driver's truck is kept in condition by experts. That is why we keep urging that you take your truck to your approved service station whenever attention is required.

### STARTING THE ENGINE (PETROL MODELS):

Hold the clutch pedal down while starting the engine. This prevents any danger of the vehicle starting before you're ready, in the event that the transmission had been accidentally left in gear. When you release the clutch, the starter does not have the burden of turning the gears in the transmission as well as cranking the engine.

Turning the ignition switch key to the right connects the ignition and fuel gauge. If the engine is cold the choke control button should be pulled out. The starter button should then be operated firmly. As soon as the engine starts to run under its own power, pressure on the starter button and on the clutch pedal should be released. In cold weather it is advisable, after the engine is running properly, to engage the clutch slowly, so that the engine will not be stalled by the thick oil in the transmission. The choke button should be pushed in immediately to its best running position, and all the way in as soon as the engine is warm enough to permit it.

Remember, if your engine has been cold, it's always best to let it idle a few minutes before starting off, and then drive slowly awhile to let it warm up thoroughly. This is important to insure proper circulation of oil to all parts, and that can't be done before your engine attains its proper operating temperature.

If the engine does not start readily when hot, the throttle control button should be pulled all the way out and the choke not operated. This will allow any unvaporized fuel which may have accumulated in the manifold or cylinders to be quickly cleared away. The throttle control button should be pushed at least most of the way in as soon as the engine starts.

For instructions on starting the Diesel Model, refer to the separate manual issued with these trucks.

### **WARNING: CARBON MONOXIDE GAS:**

The exhaust gases from all motor vehicles are highly dangerous. While carbon monoxide gas is colourless, tasteless and odorless, it is extremely poisonous. Never start or run an engine in a closed garage.

## **THE RECOMMENDED WAY TO SHIFT GEARS**

Press the clutch pedal down to the floor, then move the transmission gear shifting lever to 1st speed forward position. Next press the accelerator to speed up the engine a little and at the same time gradually relieve pressure on the clutch pedal. This engages the clutch and starts the vehicle moving. When the clutch is fully engaged (no pressure on the foot pedal), press the accelerator until the vehicle attains the desired road speed. With heavy loads or on up grades, shifts to higher gears should be made by "double-clutching", as explained below.

With the vehicle in motion, press the clutch pedal to the floor and release the accelerator at the same time. Then move the transmission gear shift lever to neutral position and relieve pressure on the clutch pedal to allow the clutch to engage, leaving the gearshift lever in neutral. This synchronizes the engine and transmission speeds. Next, depress the clutch pedal, and move the gearshift lever to the next higher speed positions (whether it be for 2nd, 3rd, 4th or 5th speed accelerator), engage the clutch and press the accelerator.

To shift into reverse, depress the clutch pedal and move the gearshift lever to the reverse position. Then release the clutch pedal, and press the accelerator pedal at the same time until the desired speed is attained.

### **SHIFTING GEARS IN TWO SPEED REAR AXLE:**

In addition to the transmission gear shifting lever, a control button mounted on the gear shift lever is provided for shifting the

gears in the 2-speed rear axle. The axle speed change is accomplished by means of an electric shift unit, which operates the shifting mechanism.

### **TO SHIFT INTO LOW SPEED RATIO:**

Keep the accelerator pedal down, and push button down. Then disengage and re-engage clutch as soon as possible, holding accelerator pedal down, or release and re-open accelerator as quickly as possible.

### **TO SHIFT INTO HIGH SPEED RATIO:**

Keep the accelerator pedal down, and pull button up. Then release accelerator, and pause until shift is completed.

### **SPLIT SHIFTING:**

To shift to a higher gear in the transmission, and at the same time from High to Low in the 2-Speed Axle, make the transmission shift in the usual way, and just before engaging the clutch push the button down.

To shift to a lower gear in the transmission, and at the same time from Low to High in the 2-Speed Axle, pull the button up, and then complete the transmission shift in the usual way.

Always start the truck with the Rear Axle in the Low Speed Ratio.

It is important to keep the accelerator down always when the control button is moved, except when split shifting to Low Speed Ratio.

### **HANDLING THE TRUCK ON HILLS:**

Too many drivers feel a certain sense of shame in shifting out of high gear when climbing a long or steep hill. Your truck needs its gears, and you should use the gears for the purpose for which they were intended. Even if a steep hill can be climbed in high, it is usually better to shift to a lower gear while the vehicle still has good momentum, thereby saving time as well as strain on the engine and minimizing the inconvenience of stalling.

Before starting down a steep or long grade, it is advisable to shift to the same gear you would use if driving up the hill. Shift to the lower gear and engage the clutch at once to hold the vehicle's speed down. Do not allow the vehicle to gain speed after shifting to a lower gear and then engage the clutch, as such an operation is almost sure to cause damage to the drive line of the vehicle.

Trucks equipped with a governor, cannot be driven faster than

the speed for which the governor is set when on level roads or when going up any grade. When going down hill, do not under any circumstances allow the truck to exceed the governed speed of the engine. Faster speeds will "rev up" the engine beyond the requirements for which it was designed and built, and is almost sure to cause damage. Use the brakes intermittently to hold the speed of the truck within limits.

## FACTS ABOUT ECONOMY

Outstanding economy has been engineered and built into your truck. **It is not exaggerating to say that it is the most economical truck in its weight class.** In fact, owners consistently report exceptional fuel oil economy. Economy, however, varies with different operating and load conditions, which cannot be controlled by the truck manufacturer, but can be controlled by the driver.

Overload and high speeds are the greatest enemies of economy. Either of these conditions increase operating and maintenance costs to the point where they become expensive rather than economical. Your truck should not be loaded above the gross laden rating recommended in this book. The Gross Laden Rating means the combined weights of the complete truck and the load it carries. To determine the gross laden weight of your truck, weigh the truck just as it operates when fully loaded.

Unnecessary high vehicle and engine speeds should be avoided. More power is required to propel a vehicle a given distance at 50 miles per hour than would be required to propel the vehicle the same distance at 30 miles per hour. Therefore, fuel and oil consumption is increased by high speeds.

Sudden starts and stops reduce fuel economy and increase maintenance costs.

Tyres should be inflated to the recommended pressure and wheel alignment maintained. Under-inflated tyres or misaligned wheels waste fuel because they increase friction between the tyres and the road, which means more power, hence, more fuel is required to move the truck.

Allowing the engine to idle while the truck is standing for any length of time will cut down fuel economy and increase operating costs.

Engine operating temperature is an important factor in engine economy. Engine operating temperatures that are above normal will increase engine oil temperatures and reduce oil economy. When the engine is continuously operated below normal operating tem-

peratures the fuel mixture is not completely burned in the combustion chambers. Some unburned fuel passes the pistons and dilutes the engine oil. Also, condensation and sludge may form in the crankcase. Dilution, condensation or sludge deteriorate oil and promote rapid wear of the engine parts, which the oil is expected to protect.

Your truck engine is equipped with advanced and outstanding features which will, under all normal operating conditions, automatically maintain the proper engine operating temperature and ventilate the crankcase. If your engine is operated under unusual conditions and normal temperatures are not maintained, economy will suffer, and it is suggested that you see your approved service station for recommendations.

Brake adjustments should be checked and the engine tuned periodically.

Maintenance and lubrication as specified in this book will insure engine efficiency and help materially to reduce frictional power loss, thereby improving economy.

## **LUBRICATION**

### **GENERAL INSTRUCTIONS.**

The present day commercial vehicles perform an entirely different type of service to that of a short time past. Higher speeds are developed and longer distances are travelled in shorter time. This type of performance demands very exacting lubrication. The necessary mechanical changes have brought about the necessity for a variety of lubricants to adequately take care of the lubrication requirements.

Proper lubrication is of vital importance to you in the economical operation of any modern automotive vehicle. We urge you to read carefully the following paragraphs and the maintenance schedule concerning this subject, so you will know just what should be used as a lubricant in the major units.

### **ENGINE OIL RECOMMENDATIONS:**

Custom, in the past, was to use heavier (higher viscosity number) oils than at present. The use of light engine oil is an aid in cold weather starting, fuel economy, and the proper lubrication of parts.

To assist in the selection of oil having the proper viscosity, the following recommendations are outlined for your information and guidance:

## FIRST 500 MILES:

During the first 500 miles, it is recommended that you use the engine oil which is in the crankcase when the truck is delivered. If necessary to add oil during the first 500 miles, No. 10-W should be used regardless of the season of the year or regardless of climatic conditions.

When your speedometer registers 500 miles, the crankcase should be drained (while the engine is warm) and refilled with No. 10-W oil during winter, or not heavier than S.A.E. 20 or No. 20-W during summer. Diesel engines use S.A.E. 20 Detergent Oil.

## NEXT 1,000 MILES:

When your speedometer registers 1,500 miles, the crankcase should be drained and refilled with the proper viscosity oil, according to the anticipated atmospheric temperature.

After these first two changes of oil (at 500 miles and 1,500 miles by your speedometer), oil changes should be made, under normal conditions, every 1,500 miles to 2,000 miles during summer, according to the following recommendations:

If you anticipate that the minimum atmospheric temperature will be:

- |  |   |
|--|---|
| Not lower than 32°F. ....                            | Use S.A.E. 30<br>(all models except Diesels). |
| As low as plus 10°F. ....                            | Use No. 20-W.                                 |
| All Diesel models use S.A.E. 20 or 30 Detergent Oil. |   |

The interpretation of this table means that the grade of engine oil specified for use in temperatures not lower than 32°F. is recommended as a general summer oil for trucks having a mileage above 1,500. It may also be used in tropical climates during the winter months where it is known that the lowest temperature will not be lower than 32°F., and where the average temperature will be close to normal summer conditions.

The use of No. 20-W oil should be confined principally to territories during the winter months where mild winter conditions are known to prevail, and where the temperature will not fall below 10°F. It must not be interpreted that No. 20-W cannot be used above 32°F., should temperatures rise and remain above 32°F. No. 20-W oil is satisfactory for use above 32°F. and a change of oil is therefore not necessary until the regular mileage interval.

## IMPORTANT:

During winter, all oils used should have a pour point or cold test below the lowest anticipated temperature that will be encountered during its use.

It is always advisable to drain the crankcase while the engine is at normal operating temperature. Oil will drain more completely when hot, and will therefore carry more of the foreign material and dirt with it if drained while the engine is warm.

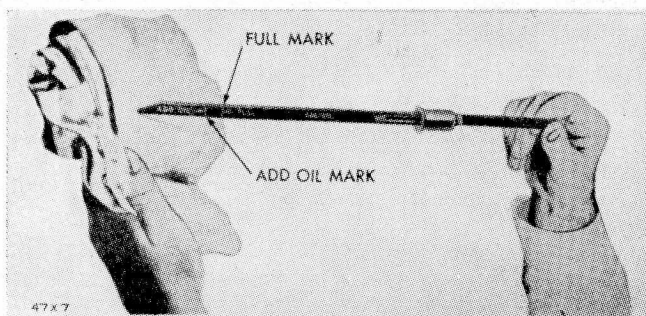

FIG. 1 — ENGINE OIL LEVEL INDICATOR

### CHECKING OIL LEVEL:

Each time you stop for fuel the oil level should be checked. The oil indicator is marked "full" and "add oil." The "full" mark shows the proper level of oil after the engine has not been run for a few hours. As soon as the engine is started running, the level will drop somewhat, due to the filling of oil passages and the filter.

Oil should not be added until the level drops to the "add oil" mark on the oil level indicator, at which time only one quart should be added.

### DUSTY ROADS AND DUST STORMS:

Driving over dusty roads or through dust storms introduces abrasive material into the engine. Air cleaners which are kept in good condition decrease the amount of dust that may enter the crankcase. However, if the oil becomes contaminated with dust or dirt, it should be drained and flushed promptly to prevent harmful engine wear. The frequency of draining depends upon the severity of the dust conditions and no definite draining periods can be recommended. It should be remembered that an oil change to eliminate abrasive dust may be considerably less expensive than to take a chance on worn engine parts.

### COLD WEATHER DRIVING:

During low temperatures, if the truck is driven for short distances of only a few miles at a time and at low speeds, moisture will condense in the crankcase and form a sludge, which may freeze and clog the oil inlet screen. Under conditions of this kind the



engine does not become sufficiently warm to expel the condensation through the crankcase ventilating system; therefore, the oil should be changed approximately every 500 miles, and under extreme conditions more often than every 500 miles.

As an alternative to this frequent change period or use of special equipment an occasional drive of 30 miles or more at higher speeds, will do much toward expelling the condensation through the crankcase ventilating system. If these longer drives are made frequently the change period may be extended to the normally recommended winter change.

### **OIL FILTER:**

The function of the oil filter on the engine is to remove dirt and foreign material from the oil in order to assist in keeping the oil clean. This is a continuous process, and the filter cartridge will continue to trap dirt until it becomes clogged. Due to the manner of connecting the oil filter to the oiling system, clogging of the filter will not stop the circulation of oil to the bearings. However, when the oil filter is clogged it ceases to filter the oil. It is, therefore, advisable to instal a new oil filter cartridge every 5,000 miles. In dusty areas it may be advisable to examine the oil and change filters more frequently, or at any time when the oil appears to be excessively dirty. The cartridge is a Micronic Filter type.

### **ENGINE OILING SYSTEM:**

#### **Air Cleaner:**

Road dust and other abrasives are filtered out of the air entering your engine through the carburettor, by means of an air cleaner. The cleaning and servicing of the air cleaner is fully covered in the maintenance schedule of the book. If properly and periodically serviced, the parts of the engine subjected to wear are protected from the abrasive action of dust and dirt. The result is a much longer engine life and the economy and efficiency is maintained for thousands of extra miles. The air cleaner should be serviced at regular intervals, even daily may be necessary under extreme conditions in dusty territory.

### **CRANKCASE VENTILATION:**

In the operation of an automobile engine, the engine oil is subjected to dilution and contamination by water, fuel, acid and other foreign elements which reduce the lubricating quality of the oil. In your engine a special ventilating system expels a large amount of these undesirable elements, but enough remain to make it advisable to drain the crankcase at the intervals recommended in this manual.

Accumulations of non-lubricating elements in the engine oil have a damaging effect on highly-finished metal surfaces. Water has no lubricating value, and is likely to freeze. Fuel thins the oil thus reducing its value as a lubricant. Acid attacks metal surfaces, causing excessive wear.

In order that the crankcase ventilation system may function efficiently and expel as much of these undesirable elements as possible, the oil filler pipe air cleaner should be serviced as recommended on the lubrication chart.

## FREQUENT STOP OR DOOR-TO-DOOR DELIVERY SERVICE:

It is essential that any internal combustion engine operates at temperatures of 140°F. or more if full economy of operation is to be obtained and more important if the formation of water and acid vapours in the crankcase is to be avoided, particularly when vehicles are engaged in frequent stop or door-to-door delivery types of service.

## MAINTENANCE SCHEDULE FOR YOUR TRUCK:

### Every 1,000-2,000 Miles.

Chassis—Lubricate the points indicated on the lubrication diagram with the recommended lubricant.

Universal Joints—Universal joints should be lubricated every 1,500 miles with gear lubricant S.A.E. 140.

Propeller Shaft Spline—The propeller shaft spline requires lubrication every 1,500 miles with semi-fluid chassis lubricant.

Carburettor Air Cleaner—Under **Normal Conditions** the air cleaner should be examined every 1,500 miles, and if the body contains dirt the air cleaner should be removed and thoroughly cleaned. Remove filter element, rinse clean in kerosene and drain. Empty the dirty oil from reservoir, clean out pan and refill to indicated level with the following viscosity engine oils:—

- \* Above 32°F. .... S.A.E. 50
- Below 32°F. .... No. 20-W

\* If S.A.E. 50 oil is not available, S.A.E. 40 or S.A.E. 30 may be used.

NOTE: Trucks operated in dusty territories will require more frequent attention. For extreme conditions, once a day may be necessary.

### **Every 3,000 Miles:**

Oil Filler Pipe Air Cleaner—Wash thoroughly in kerosene, re-oil with S.A.E. 50\* engine oil every 3,000 miles, or more frequently in dusty operation.

\* If S.A.E. 50 oil is not available, S.A.E. 40 or S.A.E. 30 may be used.

Water Pump—Lubricate as specified on the lubrication diagram.

### **Every 5,000 Miles:**

Oil Filter—The oil filter cartridge should be replaced every 5,000 miles **Under Normal Conditions** and at the time of an oil change.

In dusty areas or under severe operating conditions, it is advisable to examine the oil at frequent periods and, if found to be dirty, the filter cartridge should be changed.

After replacing the filter cartridge, the engine should be operated for a period of five minutes and a check made for leaks; the oil level should then be corrected to compensate for the oil absorbed by the new filter or filter cartridge.

### **Every 6,000 Miles:**

Engine Tune-up—The engine should receive a complete tune-up following the recommendations as set forth in the factory tune-up procedure.

Cooling System—Twice each year, the cooling system should be thoroughly cleaned and flushed by the forced reverse flow method. Refill with water and add Radiator Rust Resistor.

Battery—Remove battery terminals, clean, coat with vaseline and replace. Keep battery case and top clean at all times by wiping with a piece of waste dampened with household ammonia.

### **Every 10,000 Miles:**

Steering Gear—Inspect level of lubricant every 10,000 miles. Replenish if necessary with S.A.E. 90 low cold test fluid gear lubricant (for light truck models), add S.A.E. 140 Gear Oil for heavy truck models.

Rear Axle—Drain, flush with **flushing oil**, and then refill with the correct grade of lubricant as specified on the lubrication diagram

Transmission—Drain, flush and refill with the correct grade of lubricant as specified on the lubrication diagram.

### **TRUCK OWNERS—NOTE:**

Truck hypoid axles require an inactive type of hypoid lubricant which is a different hypoid lubricant than the active type generally used in passenger car hypoid axles.

Truck Duty Hypoid Lubricant (inactive type) is satisfactory for use in passenger car hypoid axles, but Hypoid Lubricant (active type) should not be used in truck hypoid axles.

A simple test for the proper lubricant can be made by placing a polished strip of copper in the hypoid lubricant for about 30 minutes at normal room temperature. If the copper turns black and becomes coated with a black substance, the lubricant is of the active type. If the lubricant is inactive, the copper strip may become slightly discoloured but will not become covered with a black substance.

Front Wheel Bearings—Remove hub, clean bearings and re-pack with short fibre wheel bearing grease every 15,000 miles. If, on examination, the grease is found to be in good condition, do not remove, but add grease if necessary.

Rear Wheel Bearings—Remove plugs and temporarily install lubricant gun fittings. Lubricate with short fibre wheel bearing grease, then remove lubricant fittings and install plugs.

Caution:—Do not inject more than  $\frac{1}{2}$  ounce of lubricant into each bearing

## POINTS REQUIRING LUBRICATION

(Refer to Lubrication Chart for Symbols.)

### Lubricate every 1,000 miles:

Symbols:

1. Front and rear spring shackles and pins.
2. Steering track rod and drag link ball joints.
3. King pins and bushes.
6. Propeller shaft centre bearing.
7. Dynamo wick—5 drops of **engine oil**.
8. Clutch release cross shaft—soak felt wick with engine oil.  
The clutch operating cross-shaft can be lubricated by 2 greasers which are installed in the clutch housing, one at each end of the cross-shaft (on Diesel chassis only).
9. Distributor. Felt pad—2 drops of **engine oil**.

### Lubricate every 1,500 miles:

4. Front hub bearings, one grease nipple to each hub adjacent to hub cap. Rear hub bearings, one grease nipple to each hub located on axle shaft flange.  
Except HYPOID axles in which the rear hub bearings are automatically lubricated.
5. Propeller shaft sliding joint—one grease nipple.
10. Water pump, two grease nipples on pump housing. Use special **water pump grease**.
5. Propeller shaft universal joints, one oil nipple to each joint—**use gear oil**.

### **Lubricate every 2,000 miles:**

11. Throttle controls—one or two drops of engine oil.
- 11a. Brake pedal pivot—one grease nipple. Brake pedal linkage—one or two drops of engine oil.
12. Hand brake compensator—one grease nipple.
- 12a. Hand brake linkage—a few drops of engine oil.

### **LUBRICATION OF UNITS:**

#### **Symbols:**

13. Engine—check level daily. After initial oil changes (see Lubrication General Instructions), oil changes should be made every 1,500 to 2,000 miles under normal conditions. Remove sump twice a year and clean interior; also oil screen.
14. Transmission—drain, flush and refill every 10,000 miles with S.A.E. 90 Gear Oil.
15. Rear axle (Spiral) (Single Speed)—drain, flush and refill every 10,000 miles with S.A.E. 140 E.P. Oil. Use S.A.E. 90 E.P. Oil for 2 Speed Spiral Bevel Rear Axles.
- 15a. Rear axle (Hypoid)—drain, flush and refill every 10,000 miles with S.A.E. 90 Hypoid E.P.
17. Steering—check level and refill every 10,000 miles, with S.A.E. 90 Gear Oil (for light truck models). Add S.A.E. 140 Gear Oil for heavy truck models.

Electric Shift Unit (not shown in Lubrication Chart)—every 10,000 miles check lubricant level and, if necessary to add oil, use S.A.E. 10 Motor Oil. An oil filler plug is provided in the front cover near the bottom. To change lubricant remove front cover and drain.

### **ATTENTION TO BREATHER, OIL AND AIR CLEANERS AND BATTERY:**

18. Carburettor air cleaner—every 1,500 to 2,000 miles thoroughly clean with kerosene, allow to dry. Refill reservoir with 1 pint S.A.E. 50 Oil.
19. Oil filter—change every 5,000 miles.
20. Crankcase breather—every 3,000 miles thoroughly clean with petrol, allow to dry and dip in heavy engine oil before refitting.
21. Battery—check electrolyte level weekly and "top up" as necessary, periodically clean terminals and coat with Vaseline.

### **SPECIAL ATTENTION**

Trucks operated principally on gravel or dusty roads may need lubrication attention more frequently than recommended in this Manual and should be serviced accordingly.

# LUBRICATION CHART

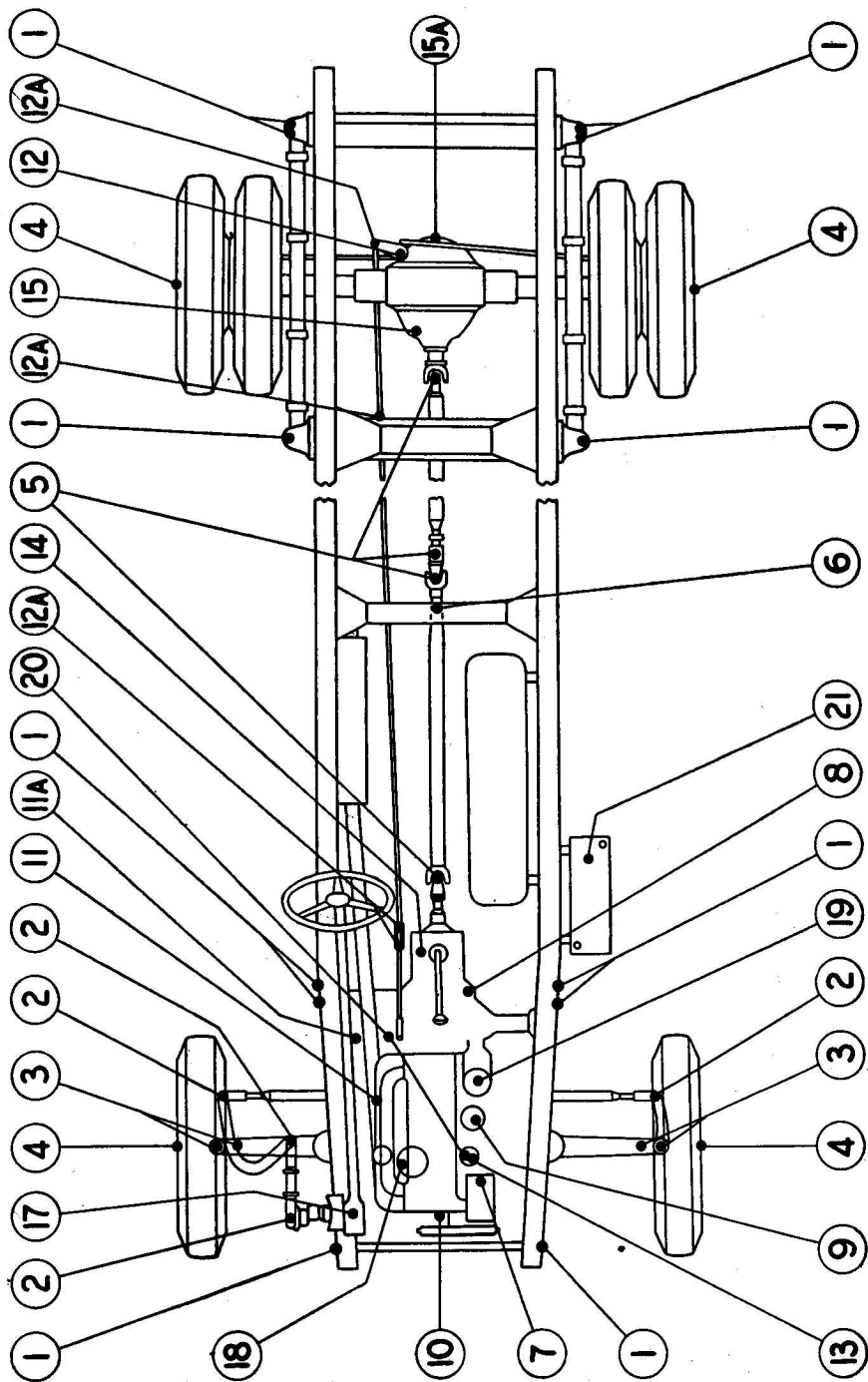

The engine unit shown here refers to petrol models only. Refer to the separate manual for Lubrication Instructions on the Diesel engine unit.

## BRAKES (MODELS 1-08, 2-26, 2-33)

### BRAKE PEDAL FREE PLAY:

Free travel of the brake pedal is important. The total free travel is made up of travel of the master cylinder piston rod before touching the piston, travel of the piston to seal the bleeder port and then travel of the shoes to take up clearance from the free running position to the position of contact with the brake drums. The total free travel of the pedal from full released position to the point where the shoes contact the drums is  $\frac{3}{4}$ " to 1". This is obtained by proper brake shoe cam adjustment.

### MINOR BRAKE SHOE ADJUSTMENT:

A quick way of adjusting the brake shoe cams is to first jack up the truck so one wheel can be rotated freely. Then, while rocking that wheel forward and backward, turn one cam adjusting nut until the shoe starts to drag on the brake drum. Then back off the adjusting nut until the shoe just clears the drum so the wheel will turn freely. This will give approximately the correct clearance between the top end of the shoe and the drum. Then make the same adjustment to the other shoe for the same wheel. It is important that these adjustments be made the same for the other three wheels. If one or more shoes have less clearance than is obtained by this adjustment there may be "brake drag," which causes overheating of the drums and possible seizure of a shoe.

### MAJOR BRAKE ADJUSTMENT:

A major adjustment will not be necessary until considerable lining wear has taken place. In order to make a major adjustment or reline the brakes, it is necessary to remove the wheels and brake drums and reset the brake shoe anchor bolts, which makes necessary the use of an approved rear wheel puller and brake shoe adjusting gauge. It is recommended that major brake adjustments be made by your approved service station, who has the necessary equipment and experience.

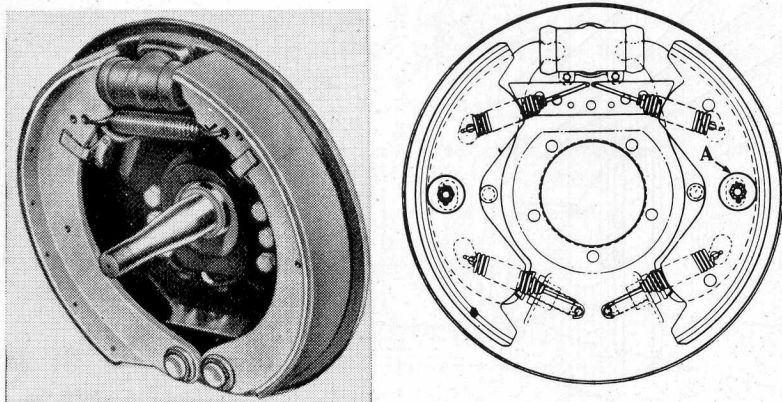

FIG. 2 — TYPICAL FRONT AND REAR BRAKE ASSEMBLIES  
LEFT FRONT BRAKE (Models 2-26 and 2-33) LEFT REAR BRAKE

## BRAKE MASTER CYLINDER:

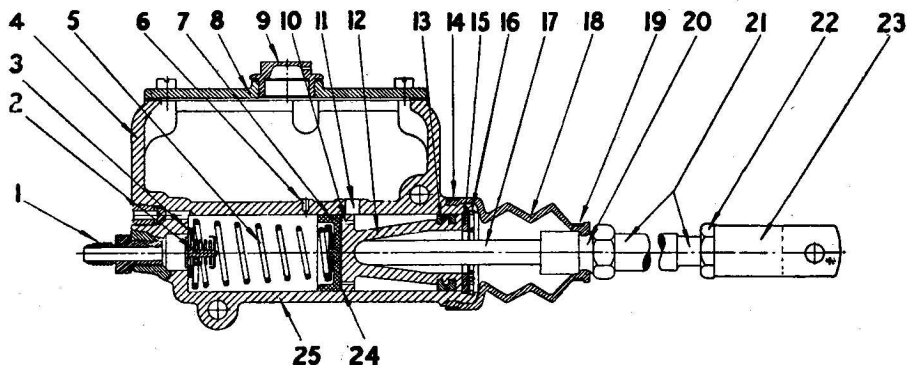

Fig. 3.

(Models 3-59, 6-71, 8-65, 8-71 and 8-71-D only.)

- |                           |                              |                              |
|---------------------------|------------------------------|------------------------------|
| 1 — Outlet pipe union.    | 10 — Port in piston.         | 19 — Boot strap (small).     |
| 2 — Inlet valve Assembly. | 11 — Master cylinder port.   | 20 — Push rod end.           |
| 3 — Inlet valve seat.     | 12 — Master cylinder piston. | 21 — Coupling rod.           |
| 4 — Reservoir body.       | 13 — Piston secondary cup.   | 22 — Coupling rod check nut. |
| 5 — Piston return spring. | 14 — Boot strap (large).     | 23 — Yoke end.               |
| 6 — Relief port.          | 15 — Piston stop.            | 24 — Piston washer.          |
| 7 — Piston cup.           | 16 — Piston stop lock wire.  | 25 — Master cylinder body.   |
| 8 — Reservoir cover.      | 17 — Piston push rod.        |                              |
| 9 — Reservoir cover plug. | 18 — Boot.                   |                              |

On 1-08 models the rear wheel brakes are the dual cylinder type. The clearance between the shoes and the drums should be .006" at both the heel and toe with this type of brake.

To adjust the dual cylinder brake the anchor bolts must be turned in the proper direction to decrease the clearance as follows:

### RIGHT REAR:

Upper and Lower—Anti-clockwise.

### LEFT REAR:

Upper and Lower—Clockwise.

### FLUID LEVEL IN BRAKE MASTER CYLINDER:

The level of the brake fluid in the master cylinder should be checked whenever brake shoe adjustment is required. However, unless there is a leak somewhere in the system it is improbable that it will be necessary to add fluid. The level should be maintained "full" or not less than "half-full." This can be inspected by removing the filler plug from the top of the master cylinder. All traces of dirt should be wiped off the cylinder and plug before it is removed, so as to avoid the possibility of dirt entering the cylinder when removing the plug. Absolute cleanliness of the fluid is essential for the safe and satisfactory operation of the brake system.



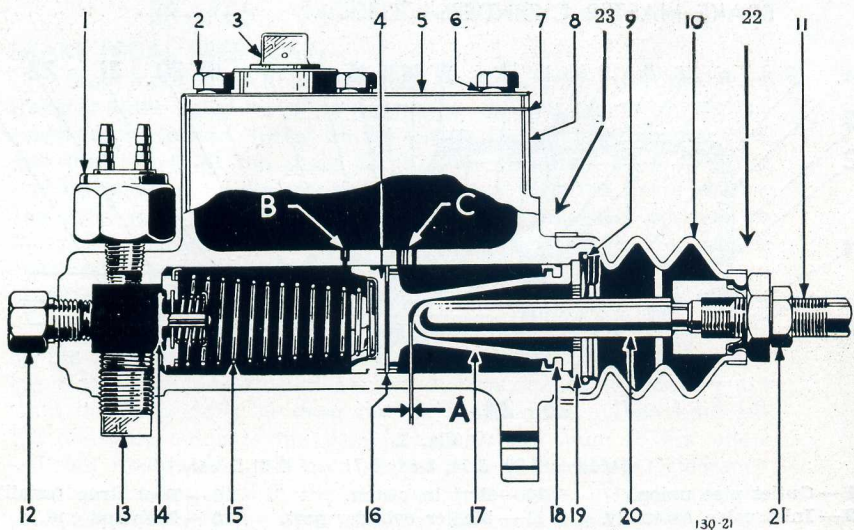

FIG. 4 — BRAKE MASTER CYLINDER (Models 1-08, 2-26 and 2-33 only.)

- |  |                                   |
|--|-----------------------------------|
| 1. Signal lamp switch.                   | 13. Hole plug.                    |
| 2. Cover Screw.                          | 14. Valve assembly.               |
| 3. Filler Plug.                          | 15. Piston return spring.         |
| 4. Piston cup.                           | 16. Piston washer.                |
| 5. Cover.                                | 17. Piston.                       |
| 6. Cover screw gasket.                   | 18. Piston secondary cup.         |
| 7. Cover gasket.                         | 19. Piston stop.                  |
| 8. Master cylinder and supply tank body. | 20. Piston push rod.              |
| 9. Piston stop lock wire.                | 21. Piston push rod and lock nut. |
| 10. Boot.                                | 22. Strap—small.                  |
| 11. Piston push rod end.                 | 23. Strap—large.                  |
| 12. Outlet connection.                   | A. Free pedal movement.           |
|  | B. Relief port.                   |
|  | C. Port.                          |

### BRAKE FLUID:

Iso Brake Fluid is the proper fluid to use in the braking system of your truck. It should be used to the exclusion of all other types of brake fluid.

### ADJUSTMENT OF HAND BRAKE: (1-08, 2-26, 2-33).

- 1—Set hand lever in fully released position.
- 2—Remove anchor screw lock wire and adjust screw so band and drum have .010" to .030" clearance. (See Specifications.)
- 3—Lock anchor adjusting screw with lock wire.
- 4—Back off large adjusting bolt nut until free.
- 5—Turn guide bolt adjusting nut after loosening lock nut until band and drum have the specified clearance.
- 6—Lock guide bolt in place with lock nut.

7—Tighten large adjusting bolt nut until tension on the guide bolt is just relieved at either end.

**CAUTION:** The groove in the bottom of the adjusting bolt nut must line up with the ridge on the bracket when proper setting is obtained.

8—Lubricate all frictional surfaces of brake control linkage and anchor bolts with engine oil.

Free play between the side of the anchor bracket at the centre of the band and the anchor must not be more than .005", otherwise band distortion may result on brake application. This free play, if excessive, may be reduced by compressing the saddle in a vise or tapping gently with a hammer against a block or anvil.

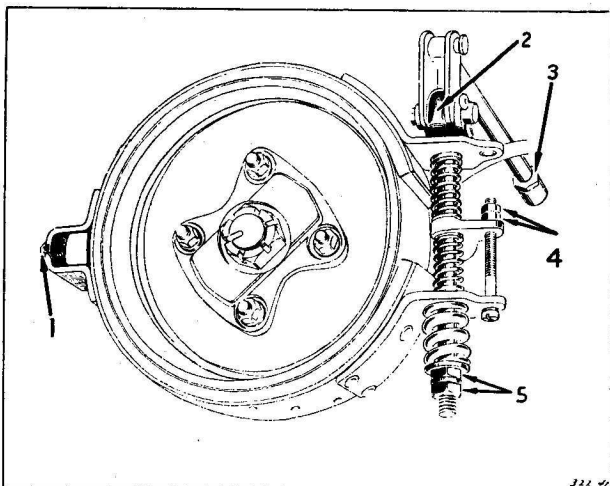

**FIG. 5 — HAND BRAKE**

- |                         |                              |
|-------------------------|------------------------------|
| 1. Band anchor screw.   | 4. Band guide bolt nuts.     |
| 2. Band adjusting bolt. | 5. Band adjusting bolt nuts. |
| 3. Rod yoke lock nut.   |                              |

**MODELS 3-59, 6-71, 8-65, 8-71, 8-71-D.**

#### **Description:**

The four wheel brakes comprise hooded shoes on the front wheels, and "2LS" (2 leading shoes) on the rear wheels. The brakes are hydraulically operated and equalised from a master cylinder, which is positioned on the right hand frame side rail.

The hand brake is connected to a compensator on the rear axle housing, and rods connect the compensator to the draw link in each transverse wheel cylinder.

#### **BRAKE PEDAL FREE PLAY:**

The brake pedal free play is  $\frac{3}{4}$ " approx. This is obtained by adjusting the rod connecting the brake pedal to the master cylinder.

## FRONT WHEEL BRAKE SHOE ADJUSTMENT:

A self-locking snail cam effects adjustment for each brake shoe. After jacking up the front axle so that both front wheels clear the ground, turn each shoe adjuster until the lining is bearing hard on the brake drum, and then slacken the adjuster slightly, allowing the wheel to rotate freely. Repeat this on all four shoes. To centralise the forward shoe, turn each wheel in a forward direction, and pump the pedal a few times. The rear shoes do not need to be centralised by the reverse rotation of the wheel as they are fixed on the anchor pin.

## REAR WHEEL BRAKE SHOE ADJUSTMENTS:

Jack up the rear axle so that both rear wheels clear the ground, turn the shoe adjuster (the wedge stem of the adjuster protrudes through the brake support plate) clockwise as far as possible and using **no undue force**. The adjuster tappets will now be seating on the cone between the flats. Next turn the adjuster anti-clockwise until a "click" is heard. This will indicate that the adjuster tappets have dropped on to the nearest flats. If the wheel now does not rotate freely, turn the adjuster until another "click" is heard. It takes  $\frac{1}{4}$  turn of the adjuster approximately for the tappets to drop from one flat to another. **Make sure always that the tappets are seating on the cone flats**, which will be indicated by a very slight back-lash on the stem of the adjuster.

Separate hand brake adjustment is not necessary. **Never** try to adjust the hand brake by adjusting or altering the hand brake operating rods.

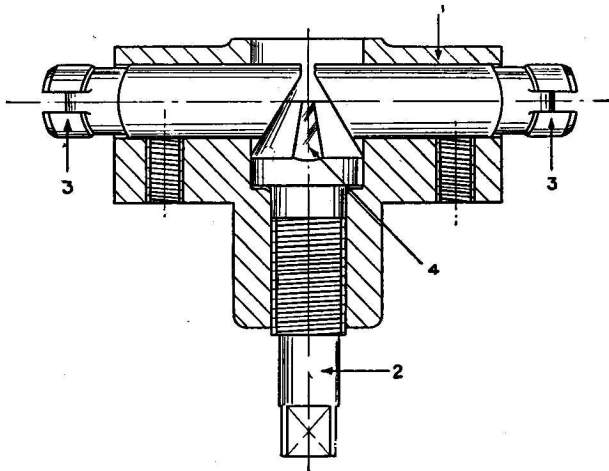

FIG. 6 — SECTION OF ADJUSTER.

- |                      |               |
|----------------------|---------------|
| 1. Adjuster Housing. | 3. Tappets.   |
| 2. Wedge with cone.  | 4. Cone flat. |

## **BRAKE FLUID:**

It is important that only genuine Iso Brake Fluid be used in the master cylinder. Any substitute or doubtful quality brake fluids can be harmful to brake system rubber parts, and the damage caused will prove costly to repair.

It is not advisable to use brake fluid bled from the system again immediately, as it is in an aerated condition.

Care and cleanliness of the complete hydraulic braking system cannot be over emphasised.

Check and clean brake parts as often as possible, and inspect for leaks. Maintain the fluid level in the master cylinder reservoir by "topping up" if necessary. There should be an air gap of  $\frac{1}{8}$ " to  $\frac{1}{4}$ " between the fluid and the under side of the filler plug.

## **BOOSTER BRAKE:**

Models 6-71, 8-65, 8-71 and 8-71-D are fitted with a Booster Brake in addition to the hydraulic brakes.

The Booster Brake consists of a slave cylinder operating in conjunction with the master cylinder to assist in brake application. Brake pedal pressure, manifold vacuum and atmospheric pressure combine to operate this unit.

The combined pressure of the vacuum chamber and that from the master cylinder acts upon the slave cylinder piston to complete the brake application.

This system, to operate satisfactorily, should be free of air leaks. The nuts and unions must be tight.

# CLUTCH

The clutch in your truck is of ample size and design to give extra long life. However, it functions by friction and if caused to slip excessively by careless operation or by "riding" the clutch pedal, sufficient heat will be generated within the clutch to shorten its life considerably.

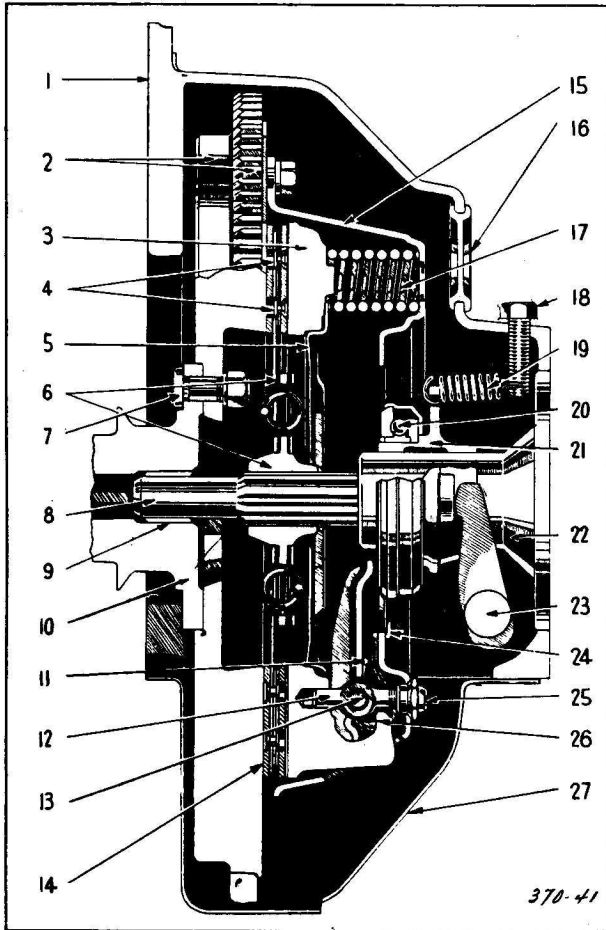

FIG. 7

(Typical of all models except 8-71-D.)

Fig. No.	DESCRIPTION
1.	Housing.
2.	Engine flywheel and ring gear.
3.	Pressure plate.
4.	Clutch lining rivets.
5.	Pressure plate baffle.
6.	Disc assembly.
7.	Engine flywheel bolt.
8.	Engine clutch shaft.
9.	Clutch shaft pilot bush.
10.	Engine crankshaft.
11.	Release lever.
12.	Release lever eye bolt.
13.	Release lever pin.
14.	Clutch lining.
15.	Cover.
16.	Housing hole plug.
17.	Pressure spring.
18.	Release bearing pull-back springscrew.
19.	Release bearing pull-back spring.
20.	Release bearing.
21.	Release bearing sleeve.
22.	Clutch shaft pinion bearing retainer.
23.	Release fork.
24.	Release lever spring.
25.	Release lever eye bolt nut.
26.	Release lever strut.
27.	Housing pan.

### CLUTCH PEDAL FREE PLAY:

Free play or free movement of the clutch pedal is necessary to compensate for wear of the clutch facing and to avoid slippage. It insures proper clearance between the clutch release bearing and the clutch release lever.

The proper amount of free play for the clutch pedal is 1 inch and is made by turning the clutch pedal adjusting collar set screws.

## THE COOLING SYSTEM

It is a recognised fact that a truck engine operates most efficiently at a certain temperature. The cooling system of your truck engine automatically maintains the most desirable engine operating temperatures under all normal operating conditions.

When the engine is started cold, a thermostat prevents the circulation of water to the radiator and a simple by-pass allows the water to circulate only in the water jackets of the engine until normal engine operating temperature has been reached. When the water temperature, as shown by the Heat Indicator, reaches approximately 157 degrees, the thermostat starts to open, allowing some water to circulate through the radiator, and at approximately 183 degrees the thermostat is fully open, allowing unrestricted radiator circulation. As the water circulates through the radiator it is cooled, but when the temperature of the water in the engine goes below the desired temperature the thermostat starts to close and retard circulation through the radiator, but not through the engine. Therefore, by automatic operation of the thermostat and by-pass the desired temperature is automatically maintained.

Water from the pump is uniformly distributed through a distributing tube and is discharged directly against the exhaust valve ports which are the hottest spots in the engine. From there the water circulates through full length water jackets around the entire area of the cylinder walls. Everything about the cooling system is automatic in operation but certain protective maintenance is necessary to insure free circulation in the system. Circulation may be stopped by a loose pump and fan drive belt, dirt in the water, or by ice.

### FAN AND WATER PUMP:

The fan and water pump are belt driven. The belt seldom needs adjusting, but your approved service station will check this when giving the truck a general inspection.

The water pump is of the packless type and the only maintenance required is proper lubrication.

Whenever adding water to the system be sure it is clean and does not contain any alkali which would form scale inside the metal parts of the system and eventually clog the passages, causing poor or no circulation. A good way to keep the cooling system clear is to have your approved service station flush it by the forced reversed flow method after draining it out.

To drain the cooling system completely, open the drain cock in the lower corner of the radiator on the right hand side and also the drain cock in the cylinder block at the bottom of the water jacket near the centre on the left side. If you are going to store

your truck or leave it idle for a long time, it is advisable to leave these drains open. For location of drain cocks on the diesel model, refer to the Service Standards.

Whenever the cooling system is drained and flushed it should be treated with "Rust Resistor" when refilling. This will retard the formation of rust in the cylinder block and corrosion of the radiator core.

If for any reason, such as insufficient water or stoppage of circulation, the engine becomes overheated (212° or more) **never pour in cold water** until the engine has been allowed to cool down below normal. The level of the liquid in the cooling system should be  $1\frac{1}{4}$ " below the bottom of the filler neck. When the fluid becomes warm, it will expand and run out of the overflow pipe if the cooling system is filled to a higher level.



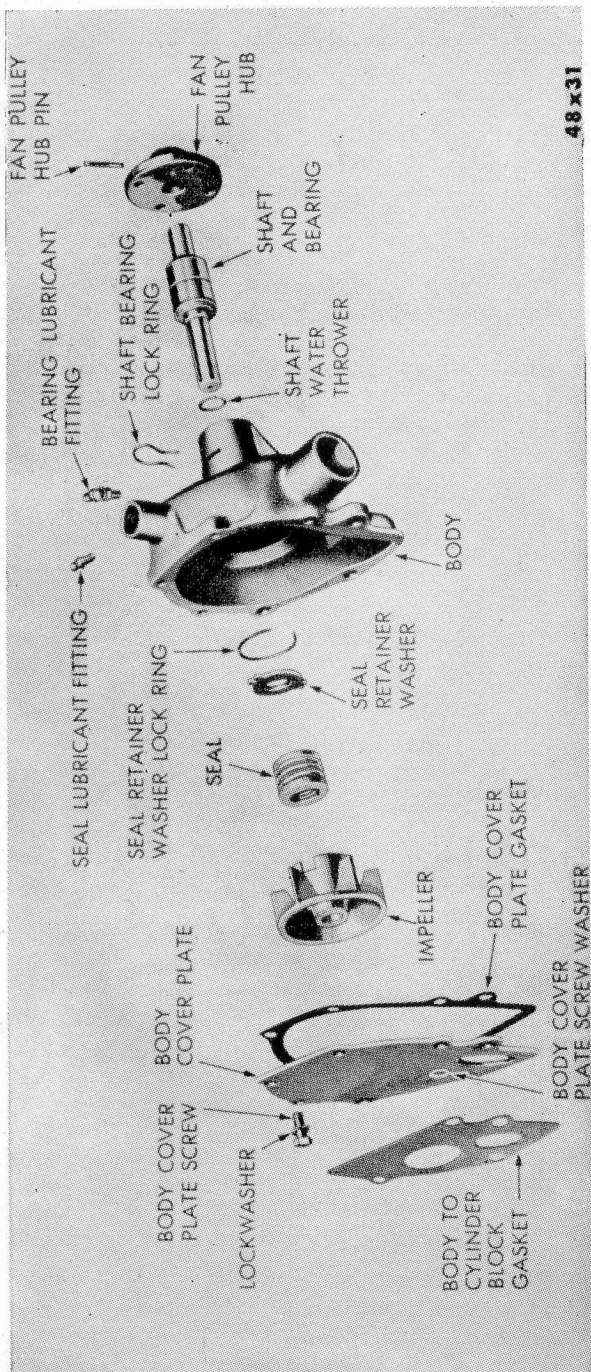

48x31

FIG. 8 — WATER PUMP (Except 8-71A-D).

## THE ELECTRICAL SYSTEM

### BATTERY:

It is easy to take care of your battery; all that is necessary is to keep it filled with distilled water. Inspect the water level frequently. Distilled water should be added to the battery about every two weeks in winter, once a week in summer.

If you should ever store your truck for an extended period, the battery should be removed and taken to a battery service station for attention during the period the truck is out of service.

**Caution:** Do not allow flames or sparks to be brought near the vent openings of the battery, since hydrogen gas, produced in the course of the battery's normal operation in the truck, may be present and might explode.

12 Volt positive earth return equipment is fitted to all petrol models.

### GENERATOR:

The increased use of electrically operated accessories has created the necessity for having a generator capable of a great current output and at the same time attend to this increased duty. The windings, bearings and other parts are all made of ample size to easily take care of this important function of generating the current required. This makes the generator last longer, even though it operates most of the time under a load. The generator is air-cooled by a vacuum fan which creates a positive circulation of air through the generator. As the volume and force of cool air vary with the speed at which the generator is being driven, a more nearly perfect operating temperature is maintained at all times.

### STARTER:

Solenoid operated starter is fitted to all petrol models.

**Caution:** Care must be taken not to engage the starter switch when the engine is running.

Diesel models are equipped with a special heavy duty starter. The Heater-Starter switch operates the starter.

### IGNITION SYSTEM:

The ignition system in petrol models consists of the distributor, the coil, the spark plugs in the engine cylinders, the ignition switch and some source of electric current which, in your truck, is the storage battery. The purpose of the ignition system is to provide an electric spark at the spark plugs at the correct time to explode the combustible fuel mixture in the cylinders for running the engine.

The operation of the engine of your truck will be seriously affected if the ignition breaker points and spark plug gaps are not kept properly adjusted and the ignition correctly timed. The results of improper ignition are sluggish engine performance, poor pick-up, and excessive fuel consumption.

**Diesels obtain ignition by virtue of temperature rise due to high compression.** Ignition is aided by an electrically operated heater plug and Ki-Gass equipment for starting from cold.

## THE ENGINE

The engine is regarded as a device for producing mechanical power. It must perform smoothly and efficiently and it must be economical, dependable over a long period of use, and require a minimum amount of maintenance.

Treat your engine with the consideration it deserves. With reasonable care and ordinary maintenance it will deliver in full measure the economical, dependable performance built into it.

The petrol engine possesses many mechanical refinements, responsive power, flexible performance and fuel economy, which makes it especially suited for hard trucking work.

The Diesel engine is the Perkins P6 type, the economical justification of which has been thoroughly proved.

## TRANSMISSION

The transmission is of the selective type and incorporates either three, four or five forward speeds and one reverse speed. The number of forward speeds vary according to the model. The transmission permits the use of several gear ratios to utilize the power of the engine more effectively at low vehicle speeds, and to permit reversing the vehicle.

The transmission is protected from friction and excessive wear through the liberal use of anti-friction ball and roller bearings. All gear shafts are mounted on roller or ball bearings which maintain proper shaft alignment and insure long gear life.

If for any reason it becomes necessary to remove the transmission assembly, it is important that pilot studs be used in the clutch housing to prevent distortion of the clutch shaft and the clutch disc. The same precaution should be taken while the transmission is being reinstalled.

Provision is made for a power take-off on all four and five speed gear boxes.

Models 1-08, 2-26 and 2-33, which are fitted with a three speed gear box, incorporate the steering column gear shift on all standard models.

A four speed gear-box is also obtainable on these models as optional equipment with floor gear shift lever.

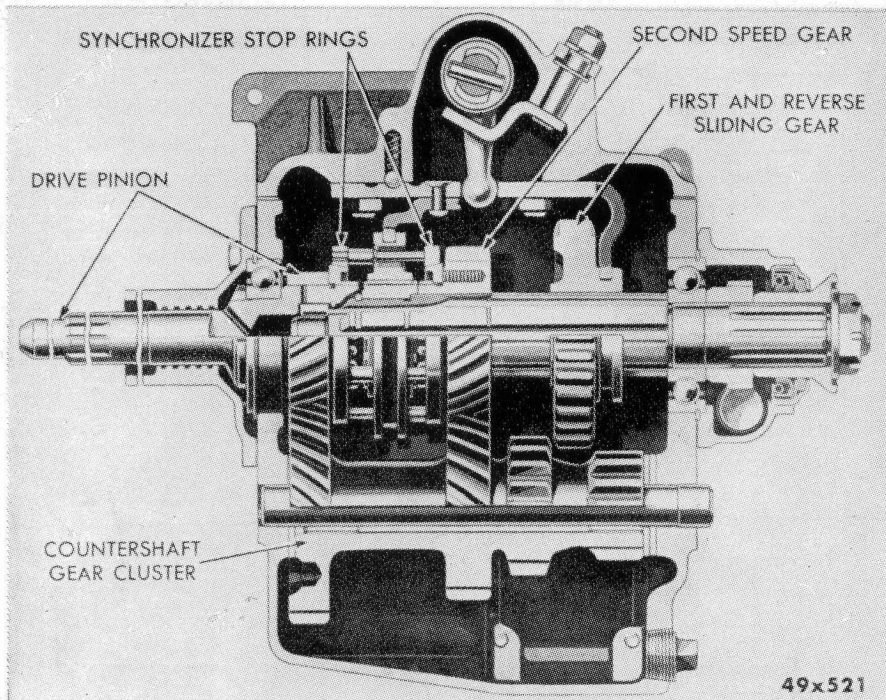

FIG. 9 — TRANSMISSION  
 (Models 1-08, 2-26 and 2-33 only.)

## REAR AXLE

The housings of the hypoid rear axles are of heavy pressed steel construction. The carrier for the differential and drive pinion at the centre of the housing is of cast steel and is fastened to the housing by large-sized cap screws which are located at close intervals around the heavy flange. The drive pinion and differential are mounted in large tapered roller bearings. The drive pinion and differential bearings should not require adjustment for an indefinite period, and, when necessary, should be adjusted by your approved service station, where the necessary special tools and shop equipment are available.

The Spiral Bevel Rear Axle (see note below for models) is of the full floating type. The crown wheel is bolted to the differential casing, and the pinion is mounted on tapered roller bearings. The housing is a one-piece pressed steel construction designed to incorporate extra strength.

NOTE: Model 3-59 (and models 6-71, 8-65, 8-71 and 8-71-D which are equipped with 2-speed Rear Axles) have the Spiral Bevel Type Rear Axle.

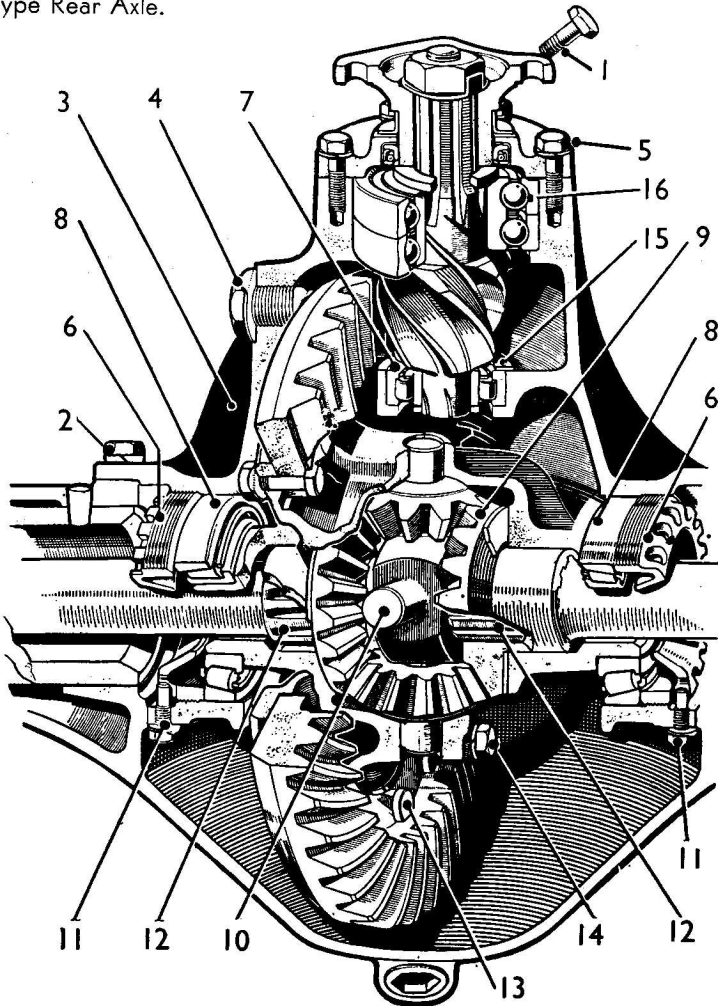

FIG. 10  
(Typical of Spiral Bevel Axles.)

- |                                     |                                    |
|-------------------------------------|------------------------------------|
| 1 — Propellor shaft flange bolt     | 8 — Differential side bearing      |
| 2 — Differential carrier set screws | 9 — Differential side gears        |
| 3 — Differential carrier housing    | 10 — Differential spider           |
| 4 — Steady pad bolt                 | 11 — Adjusting collar lock screws  |
| 5 — Pinion bearing cover set screws | 12 — Axle shaft splines            |
| 6 — Side bearing adjusting collars  | 13 — Crown wheel bolts             |
| 7 — Spigot roller bearings          | 14 — Differential case bolts       |
|                                     | 15 — Spigot bearing locating plate |
|                                     | 16 — Pinch bearing assembly        |

Models 1-08, 2-26, 2-33, 6-71, 8-65 and 8-71, which are equipped with single Speed Rear Axles, have the Hypoid Type Rear Axle.

### Special Lubrication Instructions for Hypoid Rear Axle:

The lubrication of the Hypoid Rear Axle is more critical than the Spiral Bevel Rear Axle because of stronger tooth form, and increased tooth contact, and, therefore, it is essential **that only extreme pressure lubricants** should be used.

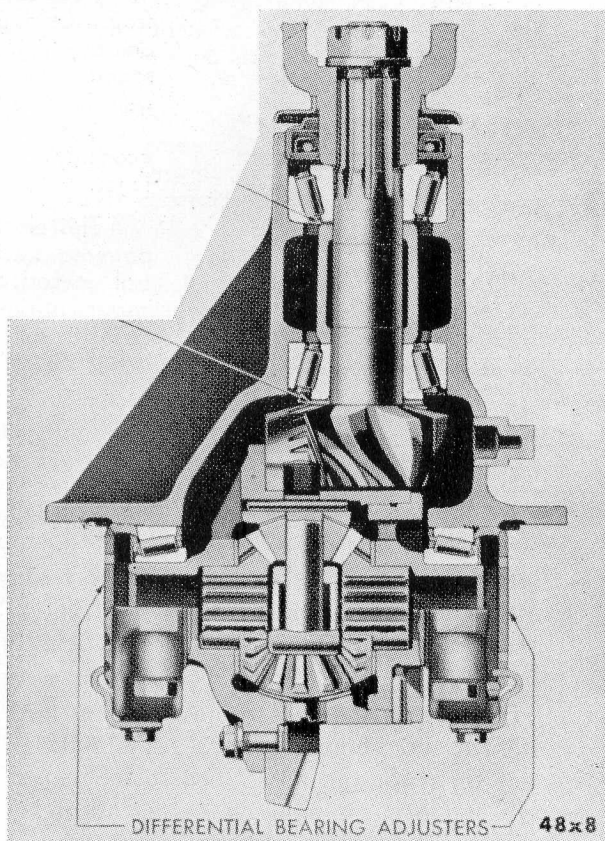
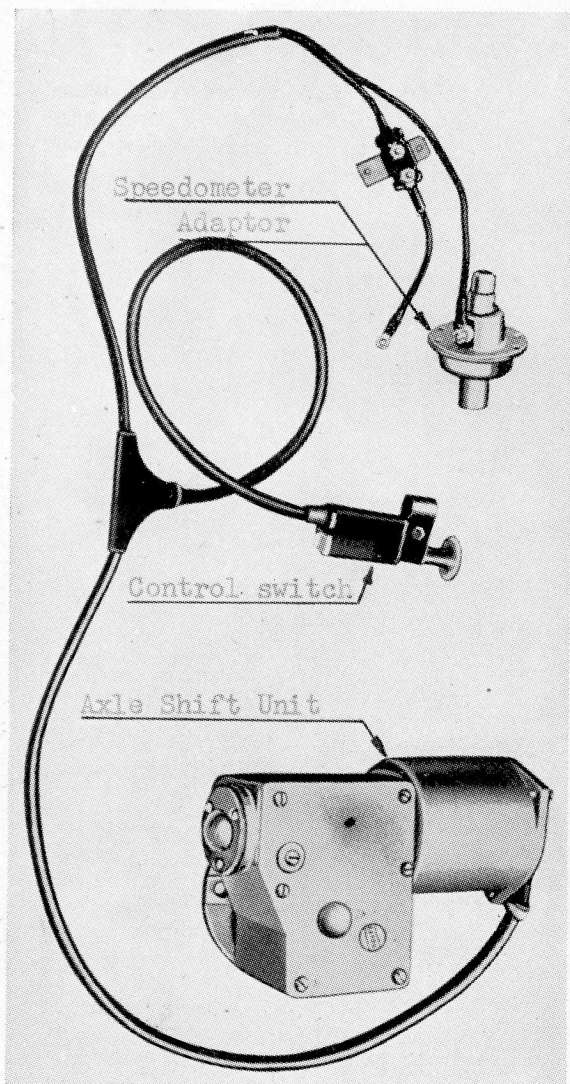

FIG. 11  
(Typical of Hypoid Axles.)

## REAR AXLE.

### THE 2-SPEED REAR AXLE:



The Eaton 2-Speed Rear Axle combines high and low ratios in the same axle, and doubles the number of gears available from the standard gearbox. It gives **speed** when you want it, **power** when you need it, and **economy** at all times.

This electrically powered shift control makes driving easier, is simple to operate, and very dependable.

The mechanism for shifting the axle consists of a control switch, an axle shift unit, and a speedometer adaptor. The control switch, located on the gear lever, has two positions, up and down. When down, the axle is in the low ratio, and when the button is pulled up the axle is in the high ratio. (See operating instructions for method of shifting). The axle shift unit consists

of a small electric motor, which when energised by the control switch effects the shift from low to high ratio or vice versa. The speedometer adaptor corrects the speedometer reading by compensating for variation in the speed of the propeller shaft between

FIG. 12

the high and low speed range of the axle. This ensures that the speedometer reading is always correct.

## **HOW TO REMOVE AND REPLACE WHEELS AND TYRES**

### **CHANGING WHEELS:**

Even though changing wheels or tyres is an unpleasant job, sometimes it is necessary under congested conditions of traffic and sometimes unpleasant weather conditions. Nevertheless, this must be done, and the engineers, in designing the truck, have done an outstanding job of making it comparatively easy. Here is all you do:—

- 1—Securely apply and lock the hand brake and, as an added precaution place blocks in front and behind the wheel on the side of the truck opposite the wheel to be changed.
- 2—Place jack under the axle.
- 3—Jack up the truck enough so you can install the fully inflated tyre.
- 4—Remove the hub cap if truck so equipped, by prying it off with a screwdriver.
- 5—Remove the capscrews or driving stud nuts which hold the wheel to the hub, with the socket wrench supplied with the tool kit.
- 6—Lift off wheel.

### **TO TIGHTEN OR CHANGE WHEELS (RIM & SIDE RING TYPE):**

It is important that the wheel driving stud nuts and axle shaft flange cap screws be tightened at regular intervals. The wheels are attached to the drums by the wheel driving studs; therefore, when wheels are removed and replaced the driving stud nuts must be tightened as tightly as possible with the special wrench furnished for that purpose.

The rear wheel stud nuts should be tightened at the pre-delivery, 500 mile and 1,500 mile inspections, and regularly every 4,000 miles thereafter, under normal conditions, more frequently under severe conditions.

### **REPLACING TYRES (RIM & SIDE RING TYPE):**

Two types of wheel side rings are used in the various truck models, a split side ring, and a solid side ring. Installation can be accomplished as follows:—

#### **SPLIT RING TYPE—**

Place the wheel over a round block which is high enough that the tyre will clear the floor when installed on the wheel. Soap the



tyre beads and then place the casing and tube over the wheel with the valve stem through the slot. Place the side ring in position with the break in the side ring away from the valve stem slot and with a suitable tool force the split lock ring into position in the groove of the wheel, working in a counter-clockwise direction until the lock ring snaps into position on the wheel. Inflate the tyre gradually to the recommended pressure

NOTE: Make certain the side ring is properly installed before inflating the tyre, otherwise the air pressure in an inflated tyre may force the side ring from its seat and cause serious personal injury.

### **SAFETY WHEEL—MODEL 1-08.**

Trucks of  $\frac{1}{2}$  ton capacity are equipped with wheels of the drop centre type, the tyre rim and wheel being integral. The tyre rim incorporates a safety feature in that the rim has a ridge which tends to hold the tyre on the wheel should a blow-out or puncture occur. The vehicle jack, which is part of the tool kit, is required to remove the tyre from the wheel rim.

#### **TO REMOVE WHEELS & TYRES:**

- 1—Set the hand brake and raise the vehicle with a jack (instructions for jack operation are on the tag attached to the jack).
- 2—Remove the hub cap, wheel hub bolts or stud nuts, and the wheel.

#### **TO DISLodge OUTSIDE BEAD:**

- 1—Remove the tyre valve core and completely deflate the tyre. Place the wheel on the ground outside up, and under either the front or rear bumper, so that the pad of the jack will index with the tyre when the jack is placed in position against the bumper as though raising the car.
- 2—Position the jack and the wheel so that the edge of the pad will bring pressure against the tyre close to the edge of the tyre rim.
- 3—Operate the jack handle forcing the tyre bead off the rim; then stand on the tyre and push the rest of the bead down into the rim well.

#### **TO DISLodge INSIDE BEAD:**

- 1—Turn the wheel over and again loosen the bead, pushing it down into the rim well.
- 2—Use a tyre lever to pry the bead on one side of the tyre off the rim. Remove the tube and then remove the tyre from the rim, with the tyre tools, in the usual manner.

## MOUNTING TYRE:

- 1—To install the tyre, inflate the tube just sufficiently to round it out. This keeps the tube in place easily and prevents its becoming pinched between the casing and the rim.
- 2—Place the tyre over the wheel and force the lower bead into the rim well. Install the tube and then force the upper bead into the rim well.
- 3—Make sure the tyre is even on the rim and that the tube is not pinched.
- 4—Lay the tyre and wheel flat to inflate. The beads will seat, snapping (with quite a sharp report) into place, against the rim flange as the tyre is inflated. If the beads do not snap into place, deflate the tyre, re-adjust the beads in the rim well and inflate again.
- 5—When the beads have snapped into place, check the tyre pressure with a gauge and inflate or deflate to the recommended pressure.

## TYRE AND WHEEL BALANCE:

Because of the possible high operating speeds of the modern vehicle, proper tyre and wheel balance has become an important factor in the correct and safe performance of the vehicle. Just as smooth performance and long life of many moving parts in the vehicle has been found to depend much upon proper balance, long tyre life becomes dependent upon proper balancing of tyres and wheels.

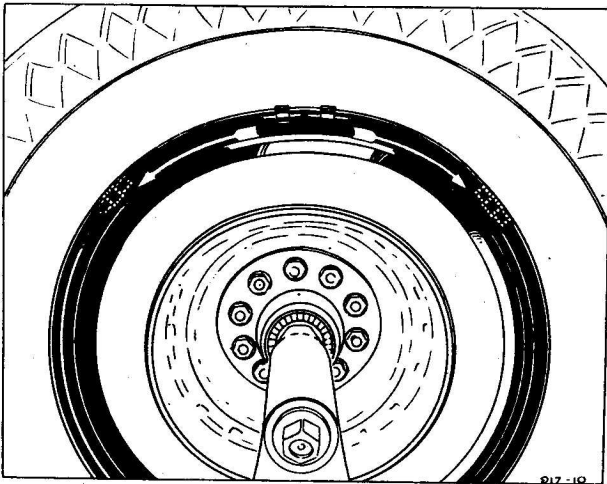

FIG. 13—BALANCING WHEEL (STATIC BALANCE)

At the time of assembly the wheels and tyres were balanced within close limits. It is recommended that you consult your

approved service station at the first sign of erratic wheel action or abnormal vibration, so the wheel and tyre balance may be inspected and corrected, if necessary, with proper equipment.

### REVERSING TYRE ROTATION:

To obtain the maximum tyre life, the tyres should be rotated, and the position changed at regular intervals.

Follow a regular pattern at approximately 3,000 mile intervals.

Front off-side to Spare, Spare to Rear off-side, Rear off-side to Front near-side, Front near-side to Rear near-side, Rear near-side to Front off-side.

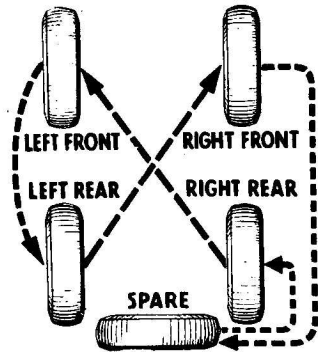

FIG. 14

## CARE OF THE FINISH ON YOUR TRUCK

### WASHING AND POLISHING THE BODY:

The finish on your truck should be washed often to keep it free from dust and road scum. This should be done by using either cold or warm water and a sponge. Your truck should always be washed in a shaded place, as washing it in strong sunlight may result in water spotting and staining, which are difficult to remove.

If the paint surface is not kept clean, the action of the elements and accumulation of dirt, road scum, corrosive salts, etc., will eventually cause damage to the finish and also present a very unattractive appearance. The more frequent washings will eliminate the necessity of using polish. If, after extended neglect, strong sunlight and the elements have caused the finish to dull, Automobile Polish can be used to restore the lustre of the finish.

### CLEANING GLASS:

In cleaning windows, windshield and other glass equipment, wash with water and wipe dry with a linen cloth or chamois. A cloth slightly dampened with household ammonia will remove the thin scum difficult to remove with water alone.

### CLEANING THE RUNNING GEAR:

Cleaning the under side of the truck and the inside of the wheels can best be done with a small, powerful stream of water from a hose. This stream dislodges mud and dirt that may have accumulated. Occasionally, the use of a stiff brush may be necessary.

## REMOVING TAR OR ROAD OIL:

Tar or road oil can be removed from the cab and body without injury to the finish by using one of the standard brands of tar remover. If the tar has hardened into lumps, soften it first by using lard, butter or kerosene, after which treat the finish with Automobile Polish.

## CAPACITIES (IMPERIAL MEASURE)

MODEL	ENGINE	COOLING	TRANS- MISSION	REAR AXLE		FUEL TANK
				Single Speed Pints	Two Speed Pints	
1-08	9 pints	4 galls.	3 pints	3	—	15 galls.
2-26	9 pints	4 galls.	3 pints	4½	—	15 galls.
2-33	9 pints	4 galls.	4 pints	4½	—	15 galls.
3-59	9 pints	4 galls.	5 pints	7½	—	15 galls.
6-71	9 pints	4 galls.	5 pints	8	12	15 galls.
8-65	9 pints	4 galls.	9 pints	8	12	15 galls.
8-71	9 pints	4 galls.	9 pints	8	16	15 galls.
8-71-D	21 pints	3½ galls.	9 pints	—	16	15 galls.

## NORMAL TYRE PRESSURES (COOL)

SIZE	PLY	PRESSURE (lbs./sq. in.)
6.50 x 16	6	40
7.00 x 16	6	40
7.50 x 16	6	40
7.50 x 16	8	45
7.50 x 20	8	55
7.00 x 20	10	60
8.25 x 20	10	60
9.00 x 20	10	65
8.25 x 20	12	70
9.00 x 20	12	75

## UNIFORM WARRANTY

No conditions or warranties, expressed or implied, shall be deemed to have been made by either COMPANY or the manufacturer of the products herein referred to and all such conditions and warranties are excluded, except the Manufacturer's Warranty against defective materials or workmanship, as follows:—

"The Manufacturer warrants each new motor vehicle manufactured by it to be free from defects in material and workmanship under normal use and service, its obligation under this warranty being limited to making good at its factory any part or parts thereof, including all equipment or trade accessories (except tyres) supplied by the Truck Manufacturer, which shall, within ninety (90) days after making delivery of such vehicle to the original purchaser or before such vehicle has been driven four thousand (4,000) miles, whichever event shall first occur, be returned to it with transportation charges prepaid, and which its examination shall disclose to its satisfaction to have been thus defective; this warranty being expressly in lieu of all other conditions and warranties expressed or implied and of all other obligations or liabilities on its part, and it neither assumes nor authorises any other person to assume for it any liability in connection with the sale of its vehicles.

"This warranty shall not apply to any vehicle which shall have been repaired or altered outside of an authorised service station in any way so as, in the judgment of the Manufacturer, to affect its stability or reliability, nor which has been subject to misuse, negligence or accident."

### CHRYSLER AUSTRALIA LIMITED KESWICK - SOUTH AUSTRALIA

Chrysler Australia Limited reserves the right to make changes in design or to make additions to or improvements in its product without imposing any obligation upon itself to install them on its products previously manufactured.

# SERVICE STANDARDS

	1-08	2-26	2-33	3-59	6-71	8-65	8-71	8-71-D
<b>AXLE FRONT</b>								
Camber .. .. .	1-1/2°	1-1/2°	1-1/2°	1-1/2°	1-1/2°	1-1/2°	1-1/2°	1-1/2°
Caster (unloaded) .. .	3° 10 mins.	1-1/2°	1-1/2°	1-1/2°	1-1/2°	1-1/2°	1-1/2°	1-1/2°
Toe-in (hub height) .. .	1/8"	1/8"	1/8"	1/8" to 3/16"	1/8" to 3/16"	1/8" to 3/16"	1/8" to 3/16"	1/8" to 3/16"
King Pin Pivot Angle .. .	4°	4°	4°	6°	6°	6°	6°	6°
<b>AXLE REAR</b>								
Clearance between Differential Side Gear and Pinion .. .	.004"-.012"	.004"-.018"	.004"-.018"	.010"-.015"	.010"-.015"	.006"-.012"	.010"-.015"	.010"-.015"
Clearance between Drive Gear and Pinion .. .	.006"-.008"	.005"-.010"	.005"-.010"	.006"-.008"	.006"-.016"	.008"-.014"	.006"-.016"	.006"-.016"
Pinion Bearing Draw Tension .. .	.0015"-.0025"	.0015"-.0025"	.0015"-.0025"	.001"-.002"	.001"-.002"	12-18 in. lbs.	.001"-.002"	.001"-.002"
Ratio—Standard .. .	4.1	4.1	4.89	5.85	6.66	6.66	6.66	NA
Teeth in Pinion .. .	10	10	9	9	9	9	9	9
Teeth in Ring Gear .. .	41	41	44	44	44	44	44	44
Ratio—Optional .. .	NA	NA	NA	NA	NA	NA	NA	NA
<b>Lubricant Capacity (Imperial Pints) :</b>								
Single Speed .. .	3	4-1/2	4-1/2	7-1/2	8	8	8	8
Two Speed .. .	—	—	—	—	12	12	16	16
<b>BRAKES—SERVICE</b>								
Brake Pedal Free Travel (total) at Pad .. .	3/4"-1"	3/4"-1"	3/4"-1"	3/4"-1"	3/4"-1"	3/4"-1"	3/4"-1"	3/4"-1"

\*Certain Rear Axles with early commencement of this series were equipped with 5.85/8.11 ratio

# SERVICE STANDARDS

	1-08	2-26	2-33	3-59	6-71	8-65	8-71	8-71-D
<b>HAND BRAKE (Transmission type)</b>								
Clearances between Drum and Band	.015"-0.030"	.015"-0.030"	.015"-0.030"	—	—	—	—	—
<b>CLUTCH</b>								
Diameter	10"	10"	10"	11"	11"	11"	11"	12"
Pedal Free Play	1"-1-1/8"	1"-1-1/8"	1"-1-1/8"	1-1/4"	1-1/4"	1-1/4"	1-1/4"	1-1/4"
<b>COOLING SYSTEM</b>								
Capacity—Imperial Gallons	4	4	4	4	4	4	4	3 1/2
Location of Drain Cock and Plug	Lower corner of radiator and lower edge of water jacket, left side of engine							
Location of Radiator and Plug	Lower corner of radiator and lower edge of water jacket, left side of engine							
Temperature for Thermostat to start opening	157°-162°	157°-162°	157°-162°	157°-162°	157°-162°	157°-162°	157°-162°	157°-162°
Temperature when Thermostat is fully open	183°-187°	183°-187°	183°-187°	183°-187°	183°-187°	183°-187°	183°-187°	183°-187°
<b>ELECTRICAL SYSTEM</b>								
Battery	One	One	One	One	One	One	One	Two
Voltage	12	12	12	12	12	12	12	6
Number of plates	9	9	9	9	9	9	9	17
Distance from top of plates to top of Electrolyte Liquid	3/8"	3/8"	3/8"	3/8"	3/8"	3/8"	3/8"	3/8"
<b>Hydrometer Reading (Temperate Climate)</b>								
Fully charged	1.275-1.285	1.275-1.285	1.275-1.285	1.275-1.285	1.275-1.285	1.275-1.285	1.275-1.285	1.275-1.285
One-half charged	1.210	1.210	1.210	1.210	1.210	1.210	1.210	1.210
Dangerously low	1.175	1.175	1.175	1.175	1.175	1.175	1.175	1.175
Freezing point of discharged battery. (Degrees F. below Zero)	5°	5°	5°	5°	5°	5°	5°	5°
Capacity in Ampere Hours	70 at 20 minute rate							
<b>DISTRIBUTOR</b>								
Breaker Point Opening	.014"-0.016"	.014"-0.016"	.014"-0.016"	.014"-0.016"	.014"-0.016"	.014"-0.016"	.014"-0.016"	136 @ 20 min. rate
No. of Cylinders for checking timing	1 or 6	1 or 6	1 or 6	1 or 6	1 or 6	1 or 6	1 or 6	—
Piston position when points open	4° A.T.D.C.	4° A.T.D.C.	4° A.T.D.C.	4° A.T.D.C.	4° A.T.D.C.	4° A.T.D.C.	4° A.T.D.C.	—
Firing Order	1-5-3-6-2-4	1-5-3-6-2-4	1-5-3-6-2-4	1-5-3-6-2-4	1-5-3-6-2-4	1-5-3-6-2-4	1-5-3-6-2-4	1-5-3-6-2-4

# SERVICE STANDARDS

	1-08	2-26	2-33	3-59	6-71	8-65	8-71	8-71-D
<b>SPARK PLUGS</b>								
Spark Plug Gap .. .. .	.028"-.032"	.028"-.032"	.028"-.032"	.028"-.032"	.028"-.032"	.028"-.032"	.028"-.032"	—
<b>ENGINE</b>								
Camshaft								
Bearing Clearance	.002"-.004"	.002"-.004"	.002"-.004"	.002"-.004"	.002"-.004"	.002"-.004"	.002"-.004"	.004"-.007"
End Play	.002"-.006"	.002"-.006"	.002"-.006"	.002"-.006"	.002"-.006"	.002"-.006"	.002"-.006"	—
Crankshaft								
Bearing Clearance	.001"-.003"	.001"-.003"	.001"-.003"	.001"-.003"	.001"-.003"	.001"-.003"	.001"-.003"	.003"-.004"
End Play	.003"-.008"	.003"-.008"	.003"-.008"	.003"-.008"	.003"-.008"	.003"-.008"	.003"-.008"	—
Thrust taken by	Rear Bear.	Rear Bear.	Rear Bear.	Rear Bear.	Rear Bear.	Rear Bear.	Rear Bear.	—
Connecting Rod								
Bearing Clearance	.001"-.003"	.001"-.003"	.001"-.003"	.001"-.003"	.001"-.003"	.001"-.003"	.001"-.003"	—
End Play	.005"-.011"	.005"-.011"	.005"-.011"	.005"-.011"	.005"-.011"	.005"-.011"	.005"-.011"	—
Cylinders								
Maximum allowable taper	.0015"	.0015"	.0015"	.0015"	.0015"	.0015"	.0015"	—
Maximum allowable out-of-round	.002"	.002"	.002"	.002"	.002"	.002"	.002"	—
Reconditioning working limits	.0005"	.0005"	.0005"	.0005"	.0005"	.0005"	.0005"	—
<b>OIL PRESSURE</b>								
At 30 m.p.h.	30-45lbs.	30-45lbs.	30-45lbs.	30-45lbs.	30-45lbs.	30-45lbs.	30-45lbs.	40-60lbs.
Pistons								
Skirt clearance for .002" x 1/2" feeler gauge (on thrust side of piston)	4 to 6 lbs. pull on scales at 70° F.	4 to 6 lbs. pull on scales at 70° F.	4 to 6 lbs. pull on scales at 70° F.	4 to 6 lbs. pull on scales at 70° F.	4 to 6 lbs. pull on scales at 70° F.	4 to 6 lbs. pull on scales at 70° F.	4 to 6 lbs. pull on scales at 70° F.	—
Piston Pins								
Clearance in Piston	Thumb push fit at 130° F. temperature	Thumb push fit at 130° F. temperature	Thumb push fit at 130° F. temperature	Thumb push fit at 130° F. temperature	Thumb push fit at 130° F. temperature	Thumb push fit at 130° F. temperature	Thumb push fit at 130° F. temperature	.001"
In Connecting Rod Bushing	Thumb push fit at normal room temperature (70° F.)	Thumb push fit at normal room temperature (70° F.)	Thumb push fit at normal room temperature (70° F.)	Thumb push fit at normal room temperature (70° F.)	Thumb push fit at normal room temperature (70° F.)	Thumb push fit at normal room temperature (70° F.)	Thumb push fit at normal room temperature (70° F.)	.001"
Piston Rings								
Gap Clearance	.007"-.015"	.007"-.015"	.007"-.015"	.007"-.015"	.007"-.015"	.007"-.015"	.007"-.015"	.011"
Side Clearance in groove	.007"-.015"	.007"-.015"	.007"-.015"	.007"-.015"	.007"-.015"	.007"-.015"	.007"-.015"	.001" to .004"
Compression								.001" to .004"
Intermediata	.0095" to .004"	.0095" to .004"	.0095" to .004"	.0095" to .004"	.0095" to .004"	.0095" to .004"	.0095" to .004"	—
Oil	.002" to .0035"	.002" to .0035"	.002" to .0035"	.002" to .0035"	.002" to .0035"	.002" to .0035"	.002" to .0035"	—
Compression Ring (top rings)	.001" to .0025"	.001" to .0025"	.001" to .0025"	.001" to .0025"	.001" to .0025"	.001" to .0025"	.001" to .0025"	—
No. per P. sten	2	2	2	2	2	2	2	—
Width	3/32"	3/32"	3/32"	3/32"	3/32"	3/32"	3/32"	—
Oil Control Rings (lower rings)								
No. per Piston	2	2	2	2	2	2	2	—
Width	5/32"	5/32"	5/32"	5/32"	5/32"	5/32"	5/32"	—



## SERVICE STANDARDS

	1-08	2-26	2-33	3-59	6-71	8-85	8-71	8-71-D
<b>VALVE GUIDES</b>								
Stem clearance in guide								
Inlet .. .. .	.001"--.003"	.001"--.003"	.001"--.003"	.001"--.003"	.001"--.003"	.001"--.003"	.001"--.003"	—
Exhaust .. .	.003"--.005"	.003"--.005"	.003"--.005"	.003"--.005"	.003"--.005"	.003"--.005"	.003"--.005"	—
Distance from top of valve guide to top face of Cylinder Block .. .	7/8"	7/8"	7/8"	7/8"	7/8"	7/8"	7/8"	—
<b>VALVE SEATS</b>								
Angle (Degrees) .. .	45°	45°	45°	45°	45°	45°	45°	—
Width .. .. .	.090"	.090"	.090"	.090"	.090"	.090"	.090"	—
<b>VALVE SPRINGS</b>								
Spring pressure compressed to 1-3/8"	107-115lbs.	107-115lbs.	107-115lbs.	107-115lbs.	107-115lbs.	107-115lbs.	107-115lbs.	—
Spring pressure compressed to 1-3/4"	40-45lbs.	40-45lbs.	40-45lbs.	40-45lbs.	40-45lbs.	40-45lbs.	40-45lbs.	—
<b>VALVE TAPPETS</b>								
Clearance to check timing—(Engine cold)—Inlet .. .	.014"	.014"	.014"	.014"	.014"	.014"	.014"	.012"
Exhaust .. .	.014"	.014"	.014"	.014"	.014"	.014"	.014"	.012"
Clearance for valves—(Engine hot)—Inlet .. .	.010"	.010"	.010"	.010"	.010"	.010"	.010"	.010"
Exhaust .. .	.014"	.014"	.014"	.014"	.014"	.014"	.014"	.010"
<b>VALVE TIMING</b>								
Inlet opens .. .	12° B.T.D.C.	12° B.T.D.C.	12° B.T.D.C.	12° B.T.D.C.	12° B.T.D.C.	12° B.T.D.C.	12° B.T.D.C.	12° B.T.D.C.
Exhaust closes .. .	6° A.T.D.C.	6° A.T.D.C.	6° A.T.D.C.	6° A.T.D.C.	6° A.T.D.C.	6° A.T.D.C.	6° A.T.D.C.	6° A.T.D.C.
<b>FUEL SYSTEM</b>								
Carburettor								
Distance from top edge of Float Chamber to top of Float—Garter .. .	5/64"	5/64"	5/64"	5/64"	5/64"	5/64"	5/64"	—
Solex .. .	1/4"	1/4"	1/4"	1/4"	1/4"	1/4"	1/4"	—
Fuel Pump								
Pounds pressure .. .	3-1/2-4-1/2	3-1/2-4-1/2	3-1/2-4-1/2	3-1/2-4-1/2	3-1/2-4-1/2	3-1/2-4-1/2	3-1/2-4-1/2	—
<b>TRANSMISSION</b>								
No. of speeds forward .. .	3 or 4	3 or 4	3 or 4	4	4	5	5	5
No. of speeds reverse .. .	1	1	1	1	1	1	1	1



*These Signs are approved by  
Chrysler Australia Limited*



*Service Stations displaying  
these Authorised Service Signs  
are your Assurance  
of Satisfaction*



*This badge identifies genuine  
MoPar parts, factory engineered  
and inspected for all Chrysler-  
built vehicles*